

40ECP55

Ø 40mm • 4-pole • 425W

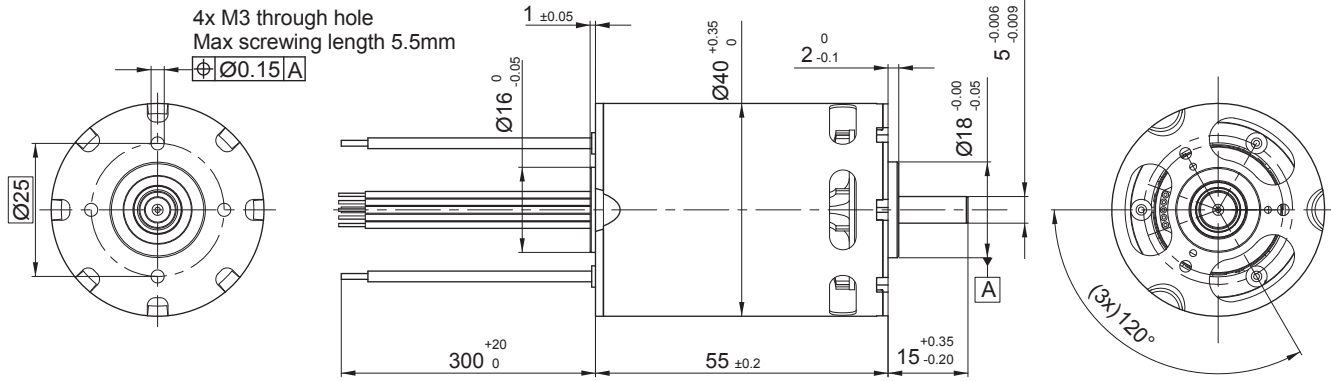

Dimensions in mm.

Electrical Data	Symbol	40ECP55 8 XX		Unit
		7	10	
1 Nominal Voltage, Max	U_n	18	18	V
2 Optimization Direction	-	Symmetrical	Symmetrical	-
3 No-Load Speed	n_0	26'310	18'000	rpm
4 No-Load Current, Typical	I_0	1'450	790	mA
5 Continuous Mechanical Power, Max (@25°C)	P_{max}	420	420	W
6 Continuous Current, Max	$I_{e,max}$	23.6	16.5	A
7 Continuous Torque, Max	$M_{e,max}$	150.2 (21.3)	150.2 (21.3)	mNm (oz-in)
8 Back EMF Constant	k_E	0.67	0.95	V/1000 rpm
9 Torque Constant	k_M	6.38 (0.90)	9.11 (1.29)	mNm/A (oz-in/A)
10 Motor Regulation	R/k^2	0.639	0.63	10°/Nms
11 Internal Resistance - Phase to Phase	R_i	0.026	0.052	ohms
12 Line to Line Resistance	R_L	0.04	0.066	ohms
13 Inductance - Phase to Phase	L	0.005	0.01	mH
14 Mechanical Time Constant	T_m	4.2	4.2	ms
15 Electrical Time Constant	T_e	0.2	0.2	ms

General Data				
16 Motor Speed, Max	$n_{e,max}$		30'000	rpm
17 Ambient Operating Temperature Range	-		-30 to +100 (-22 to +212)	°C (°F)
18 Ambient Storage Temperature Range	-		-40 to +100 (-40 to +212)	°C (°F)
19 Ball Bearings Preload	-		16 (3.6)	N (lbs)
20 Axial Static Force w/o Shaft Support, Max	-		134 (30)	N (lbs)
21 Winding Temperature, Max	-		125 (257)	°C (°F)
22 Thermal Resistance (slotless)	R_{i1}/R_2		2.3	°C/W
23 Thermal Time Constant	T_w		110	s
24 Rotor Inertia	J		66 (935)	gcm ² (oz-in-sec ² 10 ⁻⁶)
25 Hall Sensor Electrical Phasing*	-		120	Electrical °
26 Weight	-		240 (8.47)	g (oz)

* Also available without Hall sensors

No load speed for each coil

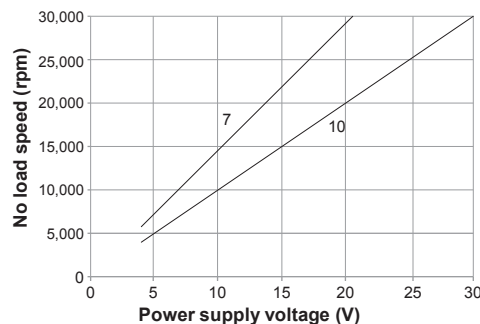

Max. continuous operation at 25°C

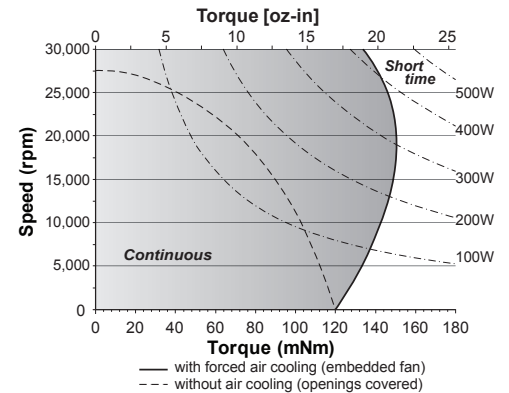

Wire	Description
Gray	Phase 1 (AWG 18)
Violet	Phase 2 (AWG 18)
Blue	Phase 3 (AWG 18)
Green	VDC (AWG 26)
Yellow	GND (AWG 26)
Orange	Hall Sensor 1 (AWG 26)
Red	Hall Sensor 2 (AWG 26)
Brown	Hall Sensor 3 (AWG 26)